

## THE TASK

When blasting parts during de-scaling, deburring, surface finishing (e.g. texturing, polishing) and parts cleaning (removal of rust, sand, paint and contaminants), dust is created on the surface of the material being treated. This dust is generated by blasting abrasives such as iron, stainless steel shots or a variety of granulate material. For a clean and safe working environment, the dust must be thoroughly extracted and separated.

When selecting an extraction system it is necessary to take into consideration the dust characteristics as well as the customer's requirement (the constantly growing product quantity at high blasting quality versus a declining efficiency).



Compact wet scrubber VDN-TE



VARIO with explosion suppression

## THE SOLUTION

We are capable of extracting explosive, combustible or harmful dust because of our dry and wet working systems. Our wide range of products ensures an optimal balance among essential system technology, investment, and operating costs. We can achieve the best solution for the corresponding blasting process.

Keller naturally emphasizes the necessity of technological fire and explosion safety measures. This would include the performance of risk analyses with extensive documentation of the system's fabrication and design.

## ADVANTAGES

- Optimized dust collection and air flow balancing which results in minimal air flows, thereby reducing investment costs, operating costs and space requirements.
- Our system design takes into consideration the latest and most important guidelines
- Customized separation systems
- Substantial knowledge of the steel process as well as the upstream and downstream manufacturing steps
- Expert aftermarket assistance with extensive service, spares inventory availability, and fast reaction times
- Air ventilation according to TRGS 560 air quality regulations
- Cost-saving explosion and fire protection alternatives
- Dust collector container exchange can be completed during system operation
- High-efficiency dust filter with BIA test certification
- Disposal systems, determined by the volume of dust
- Filtration and separation technology for finishing treatment processes

## DRY SEPARATORS FOR BLASTING PROCESSES

We extract and clean airflow volumes from a few hundred up to several hundred thousand cubic meters per hour with our graduated series of filtration units: VARIO, L-CUT or PT models.

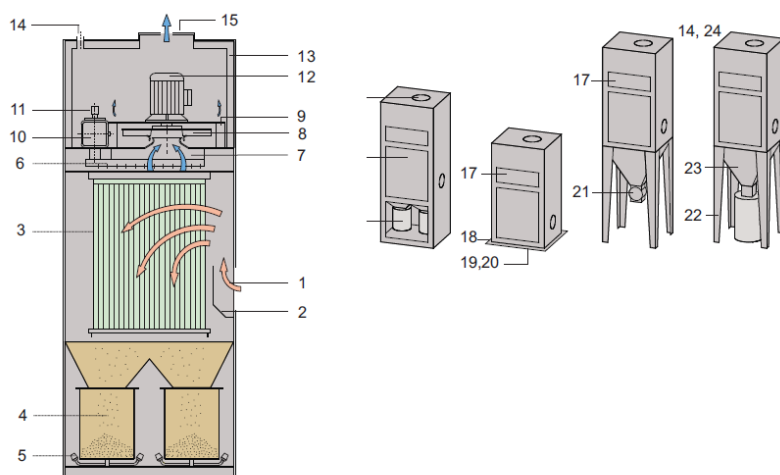

### DIAGRAM AND DESCRIPTION OF VARIO

- 1 Dirty air inlet; on optional sides of the unit
- 2 Baffle plate; at the dirty air inlet
- 3 Filter elements
- 4 Waste disposal bin
- 5 Clamping mechanism for disposal bin
- 6 Jet piping to clean the filter elements
- 7 Suction nozzle
- 8 Fan impeller; directly coupled with the motor
- 9 Radial fan
- 10 Compressed air tank
- 11 Diaphragm valves; electromagnetic
- 12 Motor with three built-in temperature probes (for motor protection)
- 13 Sound-absorbing lining
- 14 Compressed air connection for VARIO 1 - 3 with 1/2" fitting
- 15 Clean air outlet; pipe connection possible
- 16 Door to access the filter housing
- 17 Electrical switch control cabinet or terminal box
- 18 Safety device against fall
- 19 Filter housing without waste disposal device
- 20 Connecting frame
- 21 Rotary valve
- 22 Support frame
- 23 Hopper
- 24 Electrical connection

## SAMPLE INSTALLATIONS



Dry separator VARIO



Dry separator PT

## WET SCRUBBERS FOR BLASTING PROCESSES

### VENTURI WET SCRUBBER

The Venturi wet scrubber series is geared toward the separation of substances which cannot normally be separated by dry operating systems.

Foreign substances are extracted at their source and are directed by ductwork to the dirty air inlet of the separator. The spraying zone is located at this point. The air flow is extracted and intensely sprayed at the narrowest point, creating a uniform water mist which moistens the dust particles. Strong rotation in the separator housing separates the water drops from the air flow by centrifugal force. The cleaned air flows through a turbulence eliminator to the radial fan which directs the exhaust into the exhausted-air re-circulating system.

The separated dust settles and is discharged through a disposal system.

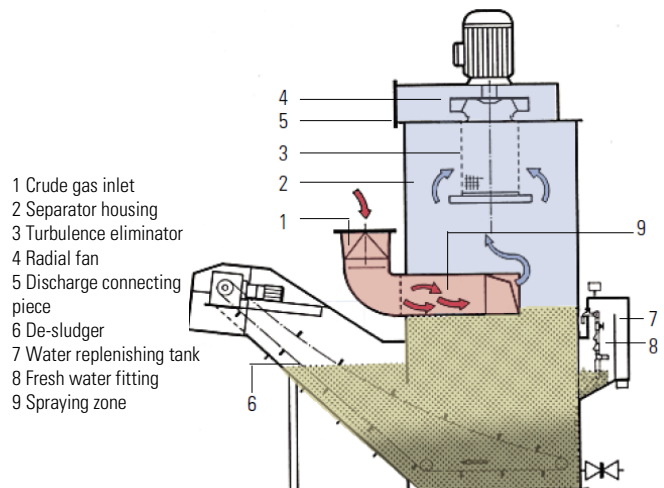

### SYSTEM TYPES

The Venturi wet scrubber type series is available in three models (VDN-E, VDN-T, VDN-AS) which are offered in various dimensions and which differ regarding their type of discharge. With this series of wet scrubbers we can extract air flows of 2.500 m<sup>3</sup>/h to 28.000 m<sup>3</sup>/h.

Keller provides the compact dust collectors in a "Z" version for particularly combustible and explosive dusts such as magnesium or aluminum alloys, with the following safety equipment:

- spark-proof fan impeller/housing combination
- electronic flow monitoring
- water level safety switch
- electrical interlock with the processing machine

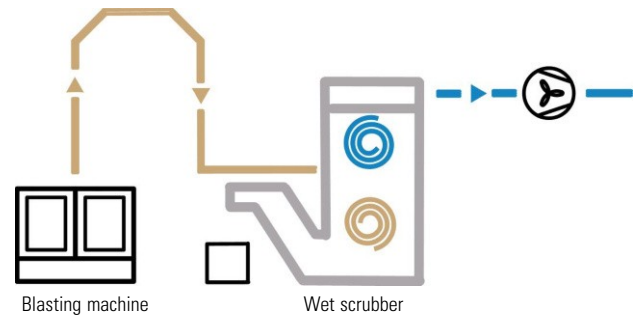

Venturi wet scrubber

# Extraction and Separation for Blasting Processes



© Keller Lufttechnik - all rights reserved. Subject to modifications 03/2013



**Keller USA, Inc.**  
2168 Carolina Place Drive  
Fort Mill, SC 29708 USA  
Phone (803) 396-2000 Fax (803) 396-2905  
E-mail [info@kellerusa.com](mailto:info@kellerusa.com)  
[www.kellerusa.com](http://www.kellerusa.com)